

# Energy Measurement Products

## ADE Product Family Overview

The Analog Devices IC (ADE) family combines industry-leading data conversion technology with a fixed function digital signal processor (DSP) to perform the calculations essential to an electronic energy meter. The portfolio includes single-phase products and polyphase products for stepper motor and LCD display meter designs, with five critical measurements available: watt, V rms, I rms, VA, and VAR.

With 175 million units deployed in the field, ADI has added to the portfolio the ADE71xx and ADE75xx product families that simplify energy meter design by providing all the features needed for an accurate, reliable, and fully functional energy meter with LCD display in a single IC.

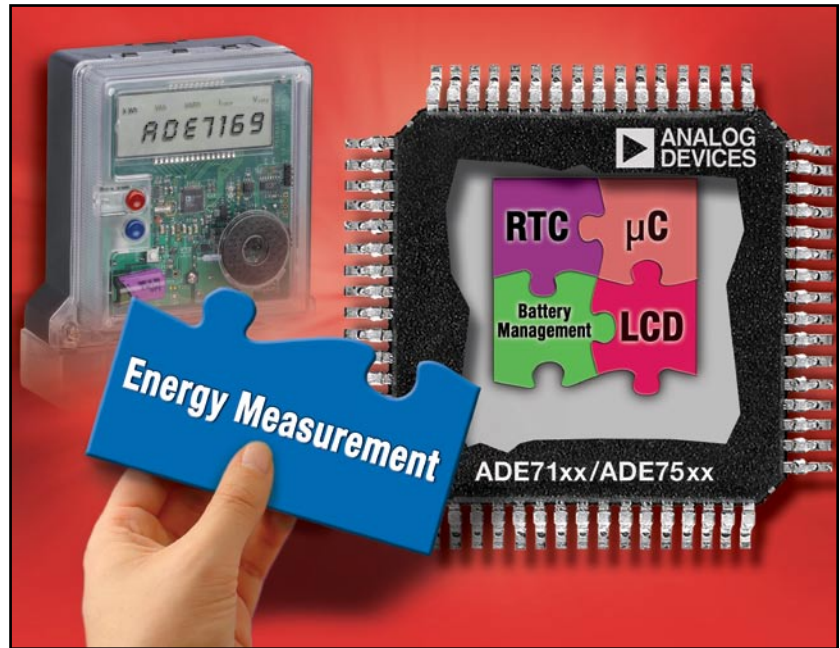

## ADE Product Family

- High accuracy exceeds IEC and ANSI standards
- Proprietary 16-bit ADCs and DSP provide high accuracy over large variations in current, environmental conditions, and time
- Reliability proven with over 175 million units deployed in the field
- On-chip reference with low temperature drift (20 ppm to 30 ppm typ)
- On-chip power supply monitoring
- On-chip creep protection (no-load threshold)
- Single 5 V supply
- Low power consumption
- Instantaneous active power output for calibration or interface to an MCU
- Miswiring or reverse power indication
- Tamper detection options

## Integrated Products for LCD Meters

- Exceeds IEC 61036/62053-21, IEC 60687/62053-23 (for multifunction products), ANSI C12.16, and ANSI C12.20
- Single chip solution integrates ADE measurement core for watts, VAR, VA, V rms, and I rms
- 8052 MCU core with flash memory
- 104-segment LCD driver with contrast control for low/high temperature visibility
- Low power RTC (1.5  $\mu$ A typ) with digital compensation for temperature performance
- Power fail and battery management with no external components
- Reference with low temperature drift (5 ppm/ $^{\circ}$ C typ)
- Noninvasive in-circuit emulation

## ADE Pulsed Output Products or Stepper Motor Display Meters

- Exceeds IEC 61036/62053-21, IEC 60687/62053-22, ANSI C12.16, and ANSI C12.20
- Active energy measurement with less than 0.1% error over a dynamic range of 500 to 1 at 25 $^{\circ}$ C
- Power consumption as low as 15 mW (typ) for single-phase products and 30 mW (typ) for polyphase products
- Built-in current channel amplifier allows the use of low resistance, low cost shunts
- Active energy, low frequency outputs directly drive electromechanical counters
- Single 5 V supply

## ADE Serial Interface Products for LCD Meters

- Exceeds IEC 61036/62053-21, IEC 60687/62053-23 (for multifunction products), ANSI C12.16, and ANSI C12.20
- Active energy measurement with less than 0.1% error over a dynamic range of 1000 to 1 at 25 $^{\circ}$ C
- Active energy and sampled waveform data
- Multifunction products provide VAR, VA, V rms, and I rms
- User-programmable power quality monitoring features
- Digital calibration for power, phase, and offset
- Serial peripheral interface (SPI) with interrupt request pin (IRQ)
- Single 5 V supply

## Value of ADE Products

### 1. Proven Technology

Analog Devices is the market leader in sales of energy metering ICs with over 175 million meters deployed worldwide with ADE products.

- Quality: Strict quality and test standards applied to ADE products throughout design and manufacturing stages ensure low meter production failure rate and uniform part-to-part characteristics.
- Reliability: Accelerated life expectancy tests on ADE products, representing more than 60 years of field usage, reduce probability of meter failure due to IC failure.
- Performance: Proprietary  $\Sigma$ - $\Delta$  ADCs provide excellent performance with an error of less than 0.1% over an extended current dynamic range.

### 2. Ease of Design

Analog Devices ADE solutions aim to simplify energy meter design, reduce system cost, and reduce time to market with:

- Integration of ADCs and fixed function DSP on a single chip leading to a single IC energy meter
- Integration of ADCs and fixed function DSP on a single chip reduces processing requirements, enabling the use of a lower cost MCU
- Embedded essential energy calculations to ensure harmonic content is included (up to 233rd harmonics for watt-hour measurement)
- Direct and flexible sensor interface without external gain amplifiers
- Unparalleled design support including detailed data sheets, reference designs, application notes, evaluation tools, and technical support
- Integrated MCU core, and all necessary peripherals, with field proven metering front end
- Greater system control with minimized current consumption in battery mode

### 3. Innovation and Choice

Analog Devices is committed to continuing its investment in the ADE product family and to enabling very competitive system costs while maintaining a high level of innovation.

- 16 patents granted or pending on innovative energy measurement technology
- Many energy measurement products currently available for single-phase and polyphase energy meters with more to come

### 4. Quality

- Samples from production lots constantly drawn for rigorous qualifications
- ADI's product analysis group continually addresses customer concerns and feedback on the quality of our products
- Constant monitoring of electrical ppm failure rate of finished products
- Electrical ppm failure rate is largely comprised of marginal parametric rejects that are fully functional but are most likely to experience failure in the field
- ADI products have a consistently low ppm failure rate that reflects the stability and high quality of the manufacturing process

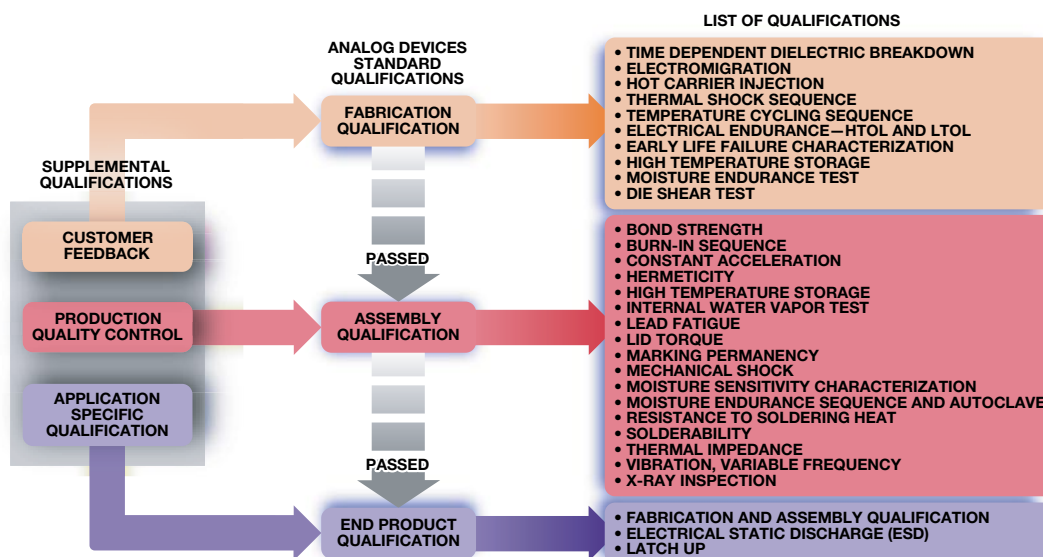

## Reliability

Analog Devices conducted a high temperature operating lifetest (HTOL) to simulate aging of ADE products in the field.

### Method—ICs subjected to 150°C for 3000 hours:

- With acceleration factor of 179×, the life expectancy correlates to 60 years at operating temperature of 60°C.
- Four main parameters monitored: reference voltage, gain error, current, and voltage channel offset.

Reliability Lifetime Predictions

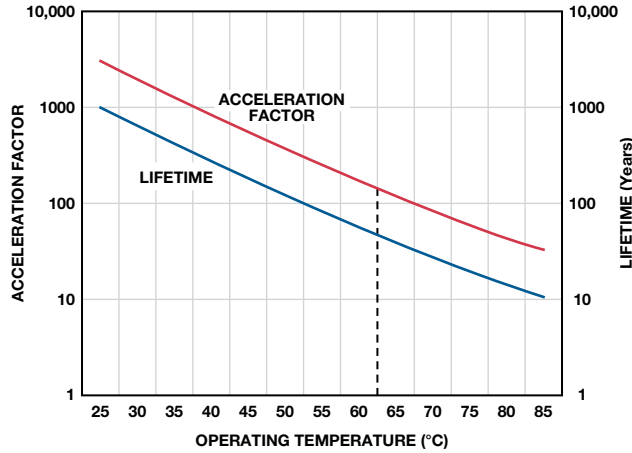

### Results—parameter distribution over time shows:

- Negligible parameter distribution shifts.
- Parameters maintain data sheet specifications.
- Zero failures.

### Conclusions from HTOL test:

- If other components in electronic meter have the same life expectancy, meter replacement is only needed every 60 years.
- Proven stability and accuracy of digital energy measurement.

*Meter manufacturers must carefully select components to ensure that the overall reliability of electronic energy meter is maximized.*

## Performance

The unsurpassed accuracy of power calculation over a very wide dynamic range, harmonics, and stability over time are the primary reasons why ADE ICs are preferred by many meter manufacturers around the world. The plot to the right highlights the typical performance of ADE ICs over a dynamic range of 1000:1 and temperature range of -40°C to +85°C. Even at a low power factor (PF = 0.5), the ICs maintain their high accuracy.

Typical Performance for ADE ICs

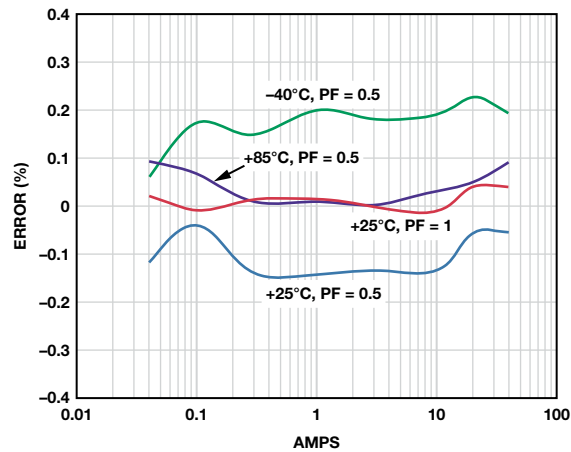

# ADE71xx and ADE75xx Product Family

## Energy Meter System Diagram

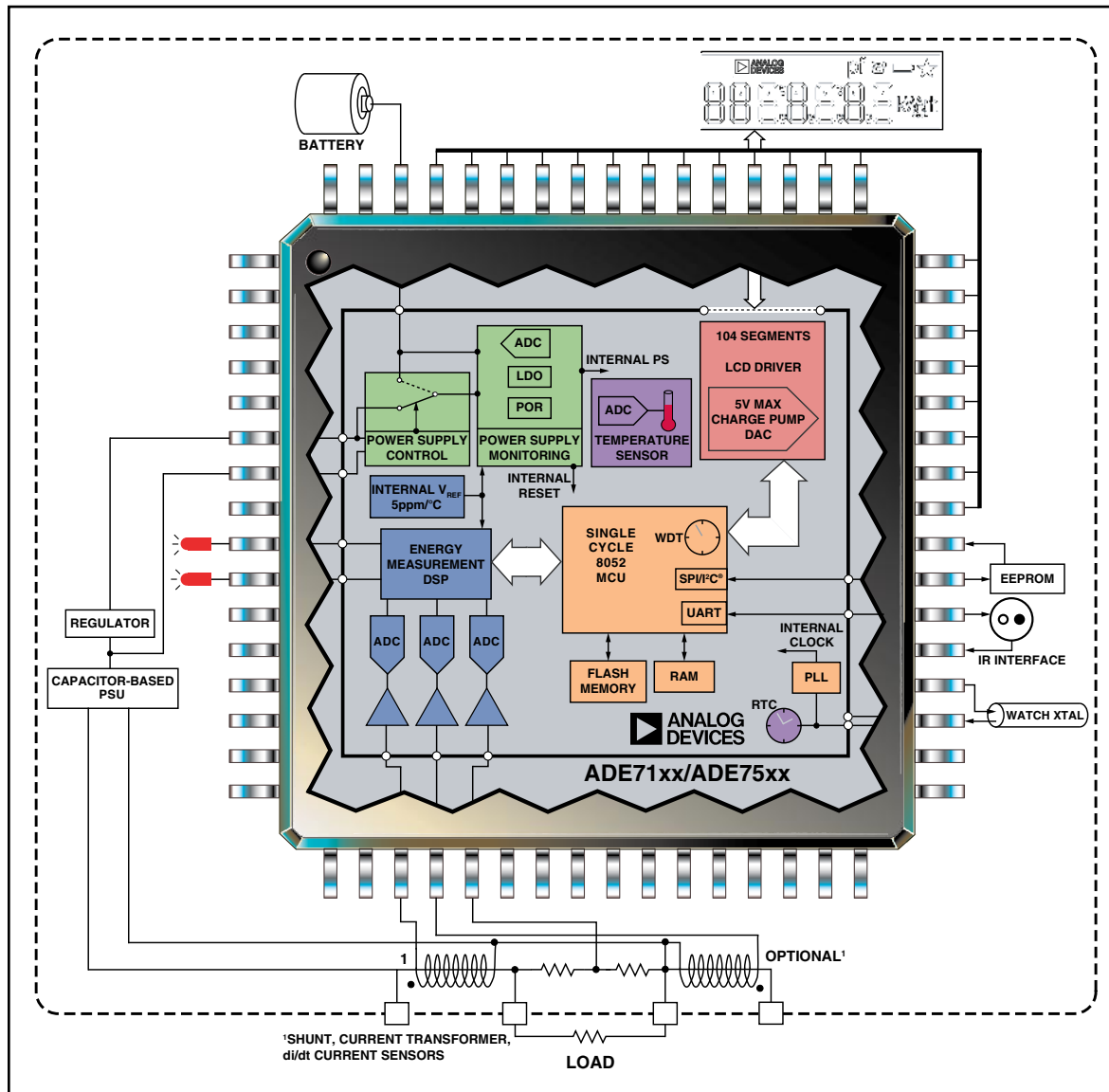

### Selection Guide

Part Number	Antitamper	W + VA + rms	VAR	di/dt	5 V LCD	RTC	Flash (kB)	Package
ADE7166	Yes	Yes	No	No	Yes	Yes	8/16	64-lead LQFP
ADE7169	Yes	Yes	Yes	Yes	Yes	Yes	16	64-lead LQFP
ADE7566	No	Yes	No	No	Yes	Yes	8/16	64-lead LQFP
ADE7569	No	Yes	Yes	Yes	Yes	Yes	16	64-lead LQFP

## ADE71xx and ADE75xx Product Family

### Energy Measurement Key Features:

- Exceeds IEC 61036/62053-21, IEC 60687/62053-22, IEC 61268/62053-23, ANSI C12.16, and ANSI C12.20
- 4-quadrant power and energy measurement for:
  - Active, reactive, and apparent
- Tampering protection
  - 2 current inputs for line and neutral
  - Tampering algorithms integrated
  - Special energy accumulation modes
- Shunt, current transformer, and di/dt current sensor connectivity enabled
- 2 high precision pulse outputs for calibration
- Power line quality: SAG, period/frequency, peak, zero-crossing
- Large phase calibration ( $5^\circ @ 50 \text{ Hz}$ )
- Wide measurement frequency bandwidth (14 kHz) for harmonic measurement

### ADE71xx/ADE75xx: Energy Measurement Computing Engine

The ADE71xx/ADE75xx family builds on Analog Devices' 10 years of experience in energy measurement to provide the best analog-to-digital converters combined with the advanced digital signal processing required to build an accurate, robust, and fully featured energy meter with LCD display.

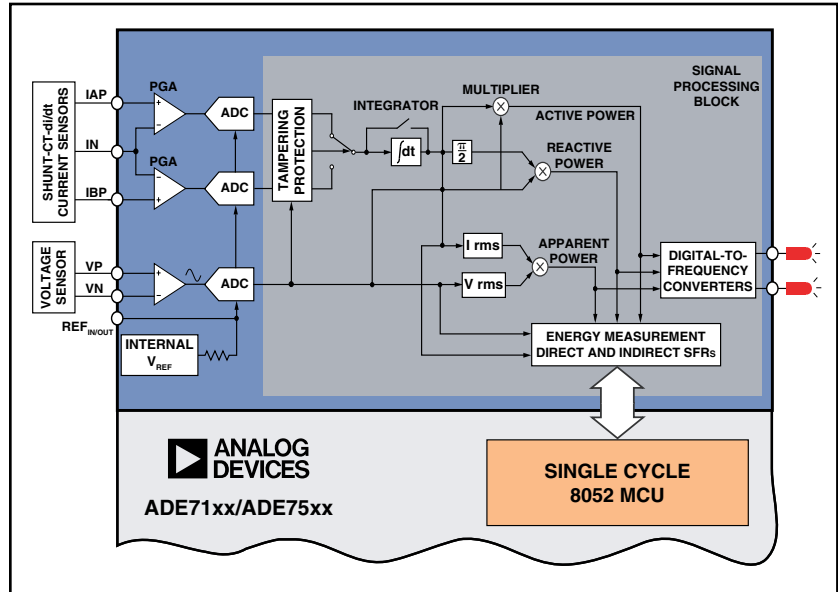

### LCD Driver Key Features:

- 104-segment LCD driver
- Adjustable LCD voltage (5 V max) independent of the power supply (2.7 V min)
- LCD freeze and hardware blink functions for low power operation in battery mode
- Low offset to minimize LCD fluid biasing

### ADE71xx/ADE75xx: LCD Driver

The ADE71xx/ADE75xx family has a unique LCD driver capable of maintaining maximum contrast on the LCD independently of the power supply level using charge-pump circuitry. This technology combined with the on-chip temperature measurement enables the lowest power operation and maximum readability of the energy meter LCD display.

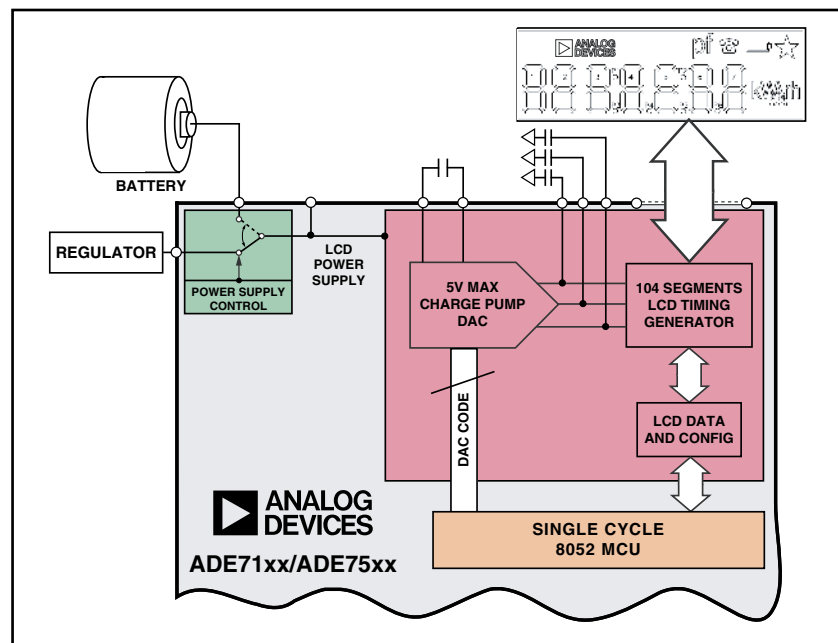

## ADE71xx and ADE75xx Product Family

### Battery Management Key Features:

- No external circuitry for battery switching
- Power supply switching based on absolute level
- Early warning of power supply collapse with SAG and preregulated power supply monitoring
- Internal power supply always valid by hardware controlled switchover to battery

### Key Features Maintained in Battery Mode:

- Real-time clock for timekeeping
- LCD display
- Temperature measurement
- Meter wake-up events such as RTC alarms, I/O, UART activities

## ADE71xx/ADE75xx: Battery Management

The ADE71xx/ADE75xx family has unique battery management features enabling low power consumption in battery mode and optimal power supply management when line voltage is lost.

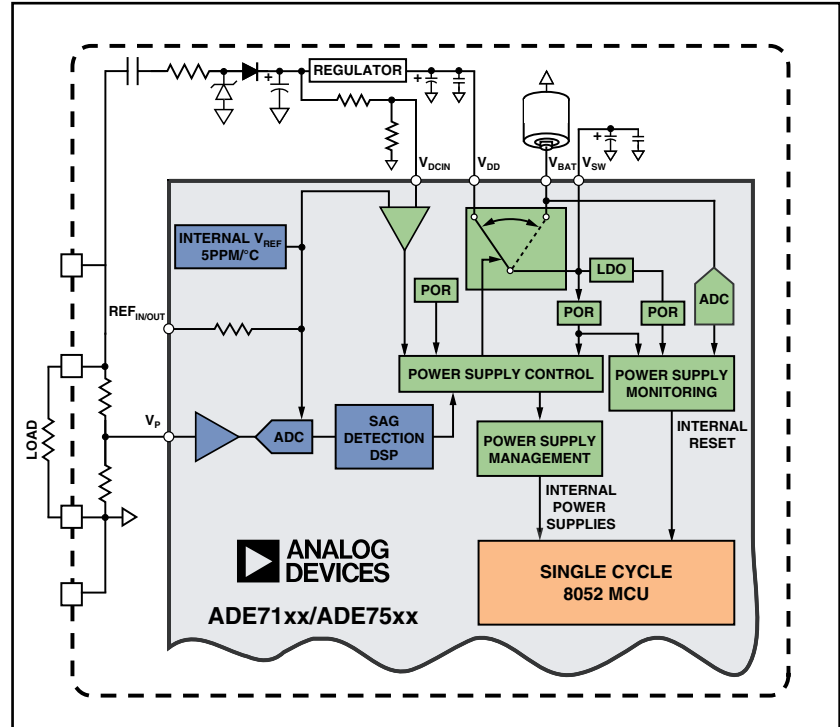

### RTC Key Features:

- 1.5  $\mu$ A current consumption
- Low voltage operation: 2.4 V
- 2 ppm/LSB digital frequency adjustment for calibration and temperature compensation
- Alarm and midnight interrupts

## ADE71xx/ADE75xx: Real-Time Clock

The ADE71xx/ADE75xx family provides a low power RTC with nominal and temperature dependent crystal frequency compensation capabilities enabling low drift and high accuracy timekeeping. The RTC functionality is also maintained at low power supply (2.4 V) and over all power supply connections, extending the operating life of the energy meter in battery mode.

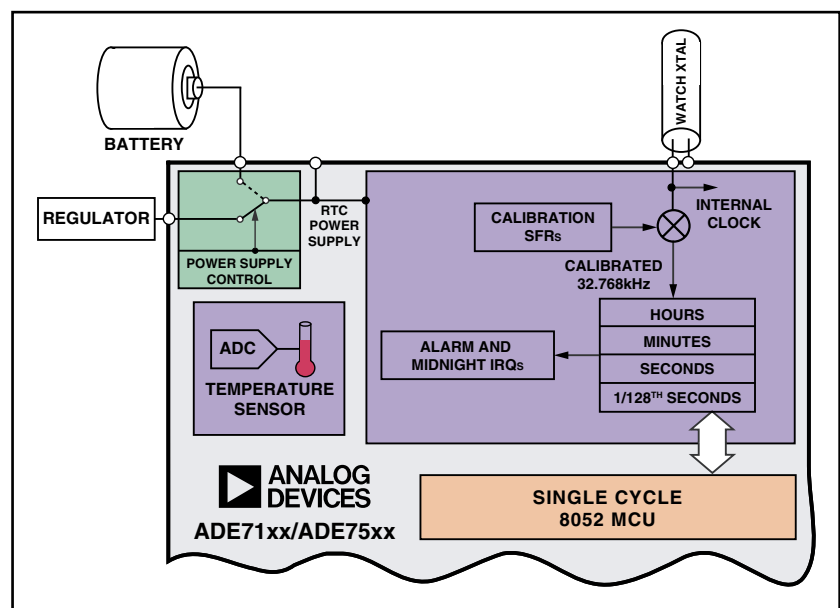

### ADE Development Tools

The ADE71xx and ADE75xx family of products share a common set of tools designed to minimize design time while improving the part understanding. These tools are comprised of:

- Energy meter reference design
- 1-pin emulator with isolated USB interface
- Isolated USB to UART debugger interface
- Downloader software
- Evaluation software
- Integrated development environment from well-known vendor
- Firmware libraries for common and part specific functions

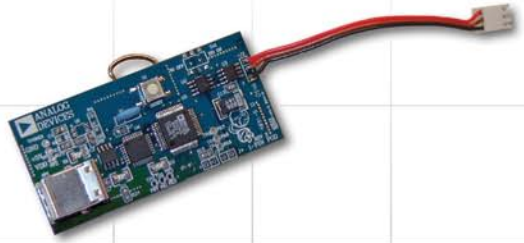

The energy meter reference design integrates the main functions of an LCD meter with IR port and RS-485 communication, battery backup, two current sensors, antitamper interface, and EEPROM interface while using the features of the ADE71xx and ADE75xx series such as battery management, antitamper detection, temperature compensated real-time clock, and LCD driver contrast.

The reference design is accompanied by code libraries and an example of system integration code allowing easy evaluation and further development of solution.

Isolated USB communication boards for debugging and emulation provide a safe solution for code development when the meter is connected to the line.

The ADE71xx and ADE75xx series can be used with integrated development environments (IDE) from open market vendors to simulate, compile, debug, and download assembly or C code. A free of charge IDE with unlimited assembly code capability and 4 kB limited C code capability is included in the evaluation kit. In addition, the part can be evaluated with a UART interface and a PC by using the versatile evaluation tools and downloader.

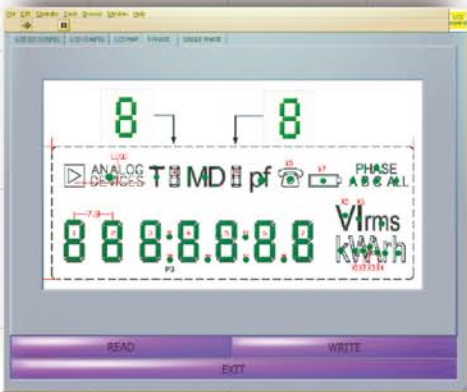
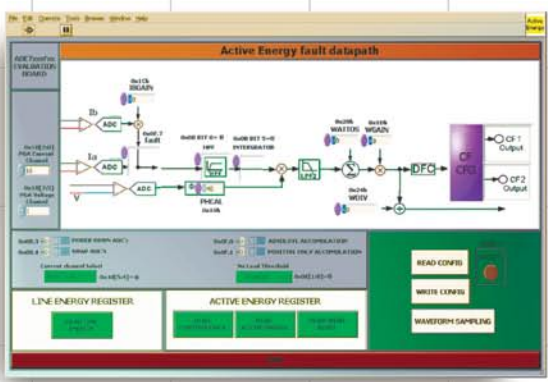
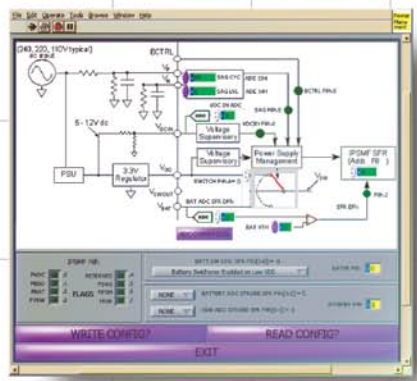

## Single-Phase Energy Metering ICs with Integrated Oscillator

The AD71056, ADE7768, and ADE7769 are single-phase ICs that provide watt-hour information using pulse outputs that directly drive a stepper motor counter.

The AD71056, ADE7768, and ADE7769 are pin-reduced versions of the ADE7755, with the enhancement of an on-chip, precision oscillator circuit that serves as the clock source for the IC. The direct interface to low resistance, low cost shunt resistors also helps to lower the cost of a meter built with AD71056, ADE7768, or ADE7769.

These products are pin compatible. The AD71056 and ADE7769 accumulate bidirectional power information, and the ADE7768 accumulates power only in the positive direction providing flexibility for various billing schemes. The ADE7769 indicates when the power is below the no-load threshold by holding the calibration frequency pin high. This is useful to indicate a tampering or miswired condition.

**Energy Metering ICs with Integrated Oscillator**

- Better than 0.1% linearity accuracy
- Watt-hour pulse output with direct drive to stepper motor counter display

Description	ADE7755	AD71056	ADE7768	ADE7769
<b>Application</b>				
Single phase	•	•	•	•
<b>Energy Measurements</b>				
Active energy (watt only)	•	•	•	•
Positive only accumulation			•	
<b>Indications</b>				
No-load indication				•
Reverse power indication	•	•	•	•
<b>System Integration</b>				
Integrated oscillator		•	•	•
<b>Package Options</b>				
SSOP	24-lead			
SOIC		16-lead	16-lead	16-lead
Lead (Pb) free	Available	Available	Available	Available

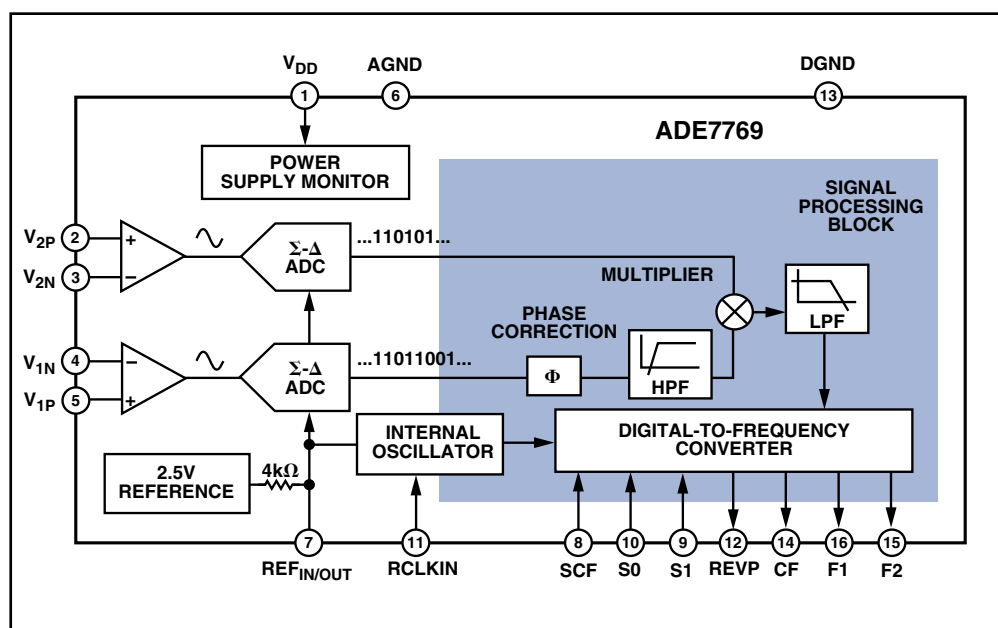



## Single-Phase Energy Metering ICs with Antitamper Features

The ADE7761B detects two common tampering conditions: “fault” condition (when loads are grounded to earth instead of connected to neutral wire or when the meter is bypassed with external wires) and “missing neutral” condition (when the voltage input and return current are missing). The ADE7761B incorporates a novel tampering detection scheme which indicates the fault or missing neutral conditions and allows the meter to continue accurate billing by continuous monitoring of the phase and neutral (return) currents. A fault is indicated when these currents differ by more than 6.25%, and billing continues using the larger of the two currents. The missing neutral condition is detected when no voltage input is present, and billing is continued based on the active current signal. The ADE7761B also includes a power-supply monitoring circuit which ensures that the voltage and current channels are matched, eliminating creep effects in the meter.



Description	ADE7751	ADE7761B
<b>Application</b>		
Single phase	•	•
<b>Energy Measurements</b>		
Active energy: 500:1 dynamic range	•	•
Active energy: 1000:1 dynamic range		•
Fault tolerant billing	•	•
Missing neutral billing		•
<b>Additional Features</b>		
Earth-fault indication	•	•
Reverse power indication	•	•
<b>System Integration</b>		
Integrated oscillator		•
<b>Package Options</b>		
SSOP	24-lead	20-lead
Lead (Pb) free	Available	Available

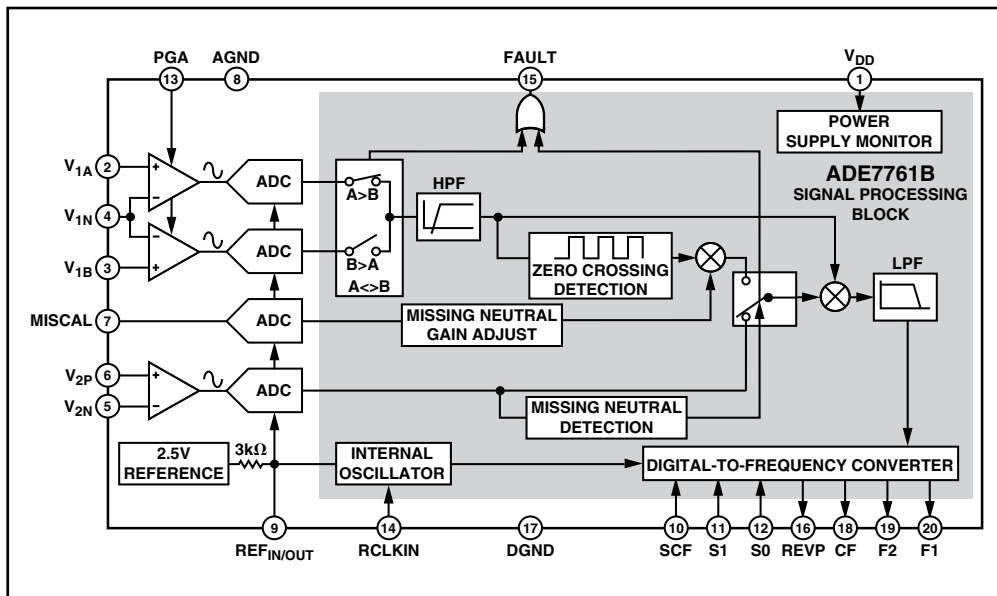

### Polyphase Energy Metering ICs with Pulse Output

The ADE7752A, ADE7752B, and ADE7762 are polyphase ICs that provide watt-hour information using pulse outputs that can directly drive a stepper motor counter. Compatible with a wide range of 3-phase grid configurations, including 3-wire and 4-wire delta and wye distributions, each of these products can be used for 3-phase commercial and industrial revenue meters or submeters, 3-phase motors or generators, industrial revenue control, and utility automation. The ADE7762 and ADE7752B are optimized for 3-phase, 3-wire applications with no-load threshold and REVP indication based on the sum of the phases.

To ensure that energy is billed properly under miswiring or tampering conditions, any of the ICs can be set to accumulate based on the sum of the absolute value in each phase. The active power accumulation is signed by default.

The ADE7762 has four additional logic output pins. These four pins drive six LEDs for prioritized indication of phase dropout and phase sequence error as well as reverse polarity per phase.

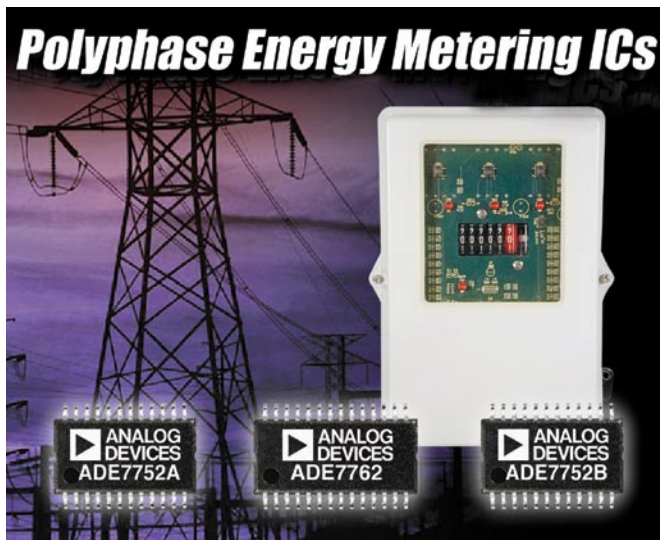

Description	ADE7752A	ADE7752B	ADE7762
<b>Application</b>			
3-phase, 4-wire wye/delta	•	•	•
3-phase, 3-wire wye/delta		•	•
<b>Power Consumption</b>			
Power consumption (mW typ)	30 mW	42.5 mW	42.5 mW
<b>Energy Measurements</b>			
Active energy (watt only)	•	•	•
Selectable signed or absolute value accumulation	•	•	•
Wide range selection table for frequency outputs	•		
High resolution selection table for frequency outputs		•	•
<b>Reverse Power Indication</b>			
Single pin (any one phase)	•		
Single pin (sum of the phase)		•	•
Three pin (per phase)			•
<b>No-Load Threshold</b>			
Sum of the phases		•	•
Per phase	•		
<b>Power Quality Monitoring</b>			
Phase drop or SAG indication (per phase)			•
Phase sequence error detection (per phase)			•
<b>Package Options</b>			
SOIC	24-lead	24-lead	28-lead
Lead (Pb) free	Available	Available	Available

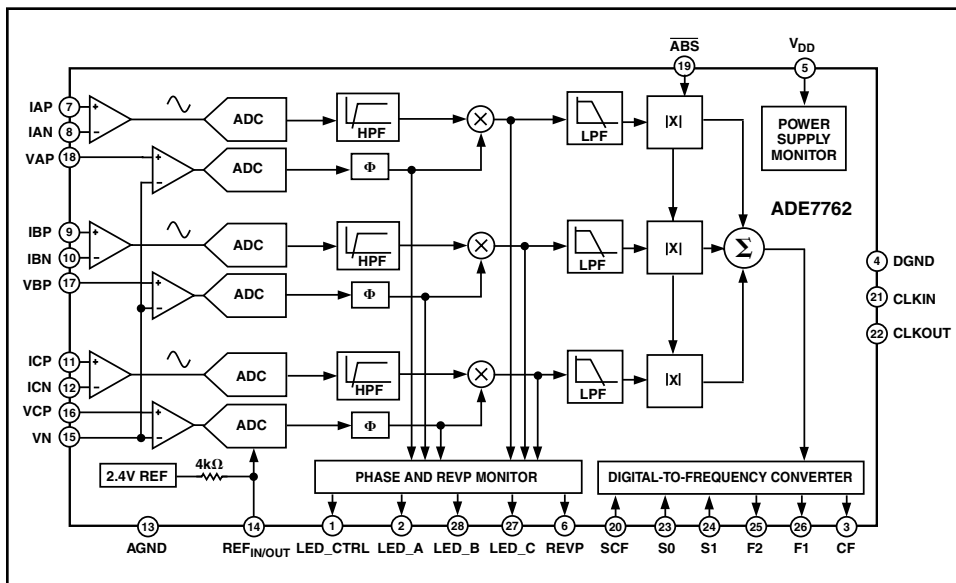

ADE7752A and ADE7752B are pin compatible with the legacy ADE7752 and have up to a 50% power consumption reduction from ADE7752. The four additional pins of ADE7762 are located at the top of the package so that the same PCB may be used with an ADE7752A-, ADE7752B-, or ADE7762-based meter.

## Single-Phase Energy Metering ICs with Serial Interface

ADI has a range of product offerings for single-phase energy measurement solutions requiring serial interface. The ADE7756 measures active energy and allows digital calibration of phase, offset, and gain through a serial port interface. The ADE7759 has a built-in digital integrator for direct interface with a di/dt sensor such as a Rogowski coil and includes the capability to interface with low resistance shunts and traditional current transformers. The ADE7753 provides active, apparent, and reactive energy measurements, and incorporates a built-in digital integrator to allow direct interface with a Rogowski coil sensor in addition to a low resistance shunt or CT. The ADE7763 provides the same functionality as the ADE7753 but without reactive energy measurement. All four of these ADE single-phase energy metering ICs with SPI are pin compatible for ease of design migration.

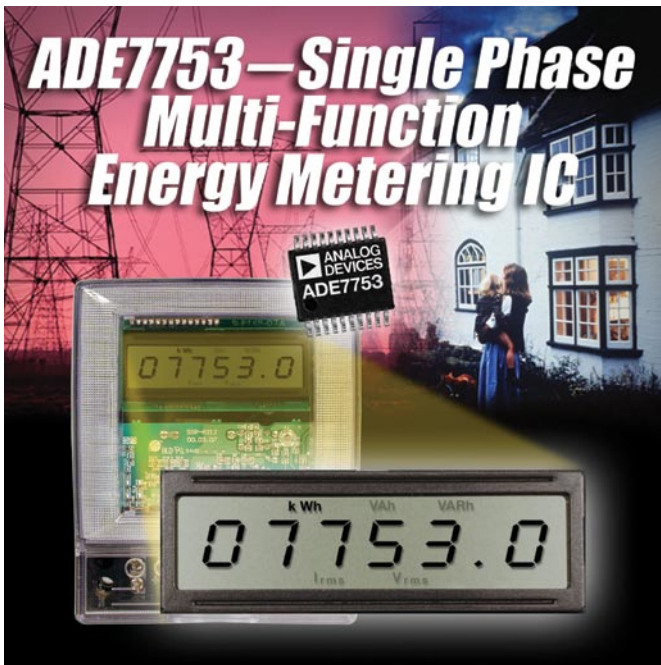

Description	ADE7756	ADE7759	ADE7753	ADE7763
<b>Application</b>				
Single phase	•	•	•	•
<b>Power Consumption</b>				
Low resistance shunt	•	•	•	•
Current transformer	•	•	•	•
Rogowski coil (di/dt sensor)		•	•	•
<b>Energy Measurements</b>				
Active energy	•	•	•	•
Reactive energy			•	•
Apparent energy, V rms and I rms			•	•
Positive only accumulation mode			•	•
Active energy pulse output	•	•	•	•
<b>Power Quality Monitoring</b>				
Current and voltage waveform samples	•	•	•	•
Power waveform samples	•	•	•	•
Peak detection			•	•
Zero-crossing and SAG detection	•	•	•	•
Frequency/period measurement			•	•
<b>Package Options</b>				
SSOP	20-lead	20-lead	20-lead	20-lead
Lead (Pb) free	Available	Available	Available	Available

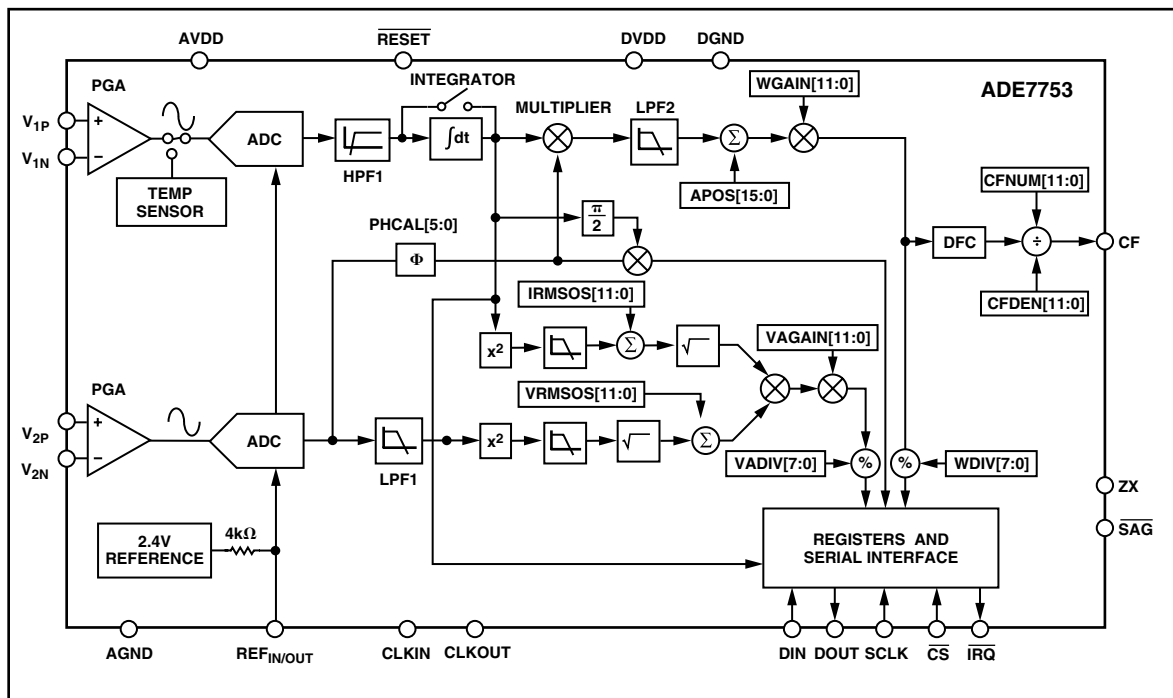



## Polyphase Energy Metering ICs with Serial Interface

ADI has a selection of product offerings for 3-phase energy measurement solutions requiring serial interface. The ADE7758 features second-order sigma-delta ADCs, and is designed for midrange 3-phase energy meters. For each phase, the chip measures active, reactive, and apparent energy, as well as rms voltage and rms current. These measurements are accessed via an SPI that allows a fully automated digital calibration. The ADE7758 interfaces with a variety of sensors, including current transformers and di/dt current sensors, such as Rogowski coils. Additionally, the ADE7758 provides a programmable frequency pulse output for both active and apparent or reactive power.



Description	ADE7754	ADE7758
<b>Application</b>		
3-phase, 4-wire wye/delta	•	•
3-phase, 3-wire wye/delta	•	•
<b>Sensor Interface</b>		
Current transformer	•	•
Rogowski coil (di/dt sensor)		•
<b>Energy Measurements</b>		
Active energy (watt only)	•	•
Reactive energy		•
Apparent energy, V rms and I rms	•	•
Per phase energy registers		•
Selectable signed or absolute value accumulation	•	•
Active energy pulse output	•	•
Reactive/apparent energy pulse output		•
<b>Power Quality Monitoring</b>		
Current and voltage waveform samples	•	•
Power waveform samples phases	•	•
Peak, zero-crossing, and SAG detection	•	•
Frequency/period measurement	•	•
Phase drop or SAG indication (per phase)	•	•
Phase sequence error detection		•
<b>Package Options</b>		
SOIC	24-lead	24-lead
Lead (Pb) free	Available	Available

Analog Devices, Inc.  
**Worldwide Headquarters**  
 Analog Devices, Inc.  
 One Technology Way  
 P.O. Box 9106  
 Norwood, MA 02062-9106  
 U.S.A.  
 Tel: 781.329.4700  
 (800.262.5643,  
 U.S.A. only)  
 Fax: 781.461.3113

Analog Devices, Inc.  
**Europe Headquarters**  
 Analog Devices, Inc.  
 Wilhelm-Wagenfeld-Str. 6  
 80807 Munich  
 Germany  
 Tel: 49.89.76903.0  
 Fax: 49.89.76903.157

Analog Devices, Inc.  
**Japan Headquarters**  
 Analog Devices, KK  
 New Pier Takeshiba  
 South Tower Building  
 1-16-1 Kaigan, Minato-ku,  
 Tokyo, 105-6891  
 Japan  
 Tel: 813.5402.8200  
 Fax: 813.5402.1064

Analog Devices, Inc.  
**Southeast Asia Headquarters**  
 Analog Devices  
 22/F One Corporate Avenue  
 Shanghai, 200021  
 China  
 Tel: 86.21.5150.3000  
 Fax: 86.21.5150.3222

