

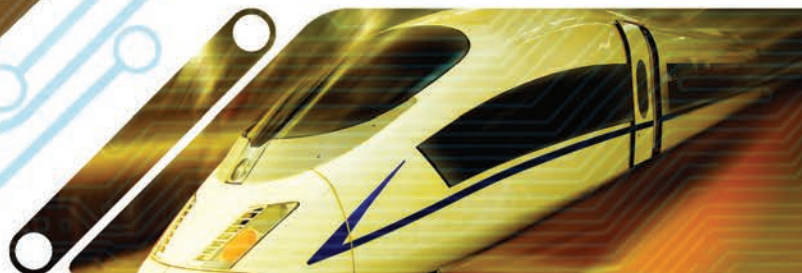

MEMS Inertial Measurement Units for Complex Motion Capture and Processing



Industrial, healthcare, and military/aerospace designs are increasingly deploying MEMS inertial measurement units (IMUs) for highly precise control, automation, and positioning applications.

High Performance, Industrial, and Tactical-Grade MEMS IMUs

- Improve accuracy over alternative non-inertial sensing technologies
- Reduce cost and size as compared to legacy sensing and measurement techniques, such as fiber optic gyroscopes (FOGs)
- Improve reliability, or add redundancy
- Enable new applications that previously were cost prohibitive

Applications are diverse, but most exist within challenging environments that are often characterized by multiple interference or noise sources. Achieving highly accurate motion discernment within these often severe environments requires orders of magnitude better stability than available from consumer grade inertial sensors.

ADI is the industry leader in high performance MEMS inertial sensing technology. Our solutions combine sensor and signal conditioning/processing technologies, providing optimal system-ready motion sensors for industrial, healthcare, and military/aerospace applications, and more.

Technology and Innovation Focused on Highly Precise Motion Sensing

Most motion sensors can provide moderate levels of accuracy within a controlled environment, but very few technologies can provide high levels of accuracy under highly dynamic environmental conditions. ADI's MEMS sensor core and integration technologies have been developed specifically to address the stringent requirements of these demanding environments.



STABILITY UNDER COMPLEX MOTION/ENVIRONMENTS

MEMS Sensor Core

ADI's proprietary quad-core MEMS gyroscope technology suppresses *g*-effect bias influences directly at the sensing element without the need for elaborate and costly mechanical/packaging suppression. ADI's MEMS sensor design, development, and manufacturing process enables inherently stable linearity—a crucial technical advantage—while still minimizing cost, power, and size impact.

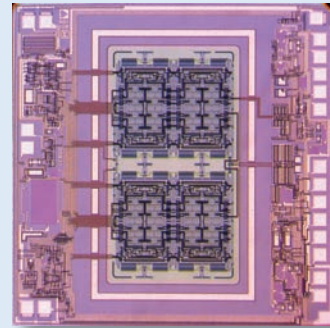

Sensor Integration and Fusion

iSensor® MEMS IMUs integrate up to ten precision motion/positioning sensors from a single interface, in a volume one-tenth that of traditional military-grade IMUs. Leveraging ADI's signal processing expertise, sensors are optimally combined to maintain maximum bandwidth and phase matching, even in complex and dynamic environments. All ADI MEMS IMUs share a common electrical interface that users can access for configuration and digital filtering options.

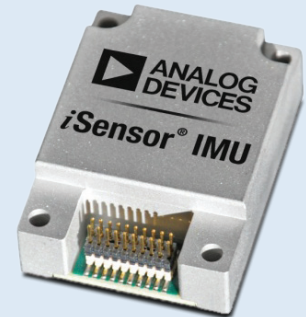

Full Factory Test and Calibration

Every *iSensor* MEMS IMU is uniquely and precisely factory calibrated, resulting in highly stable sensor outputs under all conditions and eliminating the need for customer motion testing. Unique calibration constants are internally stored and processed with embedded real-time compensation. Characterization and qualification programs are designed to ensure device robustness in demanding physical environments, and customers can access all required operational details via comprehensive product data sheets.

Vibration Rectification	0.0001 (°/sec/ <i>g</i> ²)
Bias Tempco	0.0025 (°/sec/°C)
Cross-Axis Sensitivity	0.09%
Nonlinearity	0.01% FS
Bandwidth	330 Hz

Analog Devices MEMS Inertial Measurement Unit Portfolio

ADI MEMS IMUs are offered with 4 to 10 degrees of freedom, and all are interface compatible. With four-plus generations of performance and integration advancement, ADI technology is able to fully optimize each sensor's individual and combined response to varied and complex motion, removing a level of risk from any subsequent system development.

Millions of sensor units under the Analog Devices *iSensor* brand have been deployed worldwide in a range of applications, including agricultural machinery, surgical navigation, medical imaging, unmanned aerial vehicles (UAVs), missiles, broadband communications, and robotics.

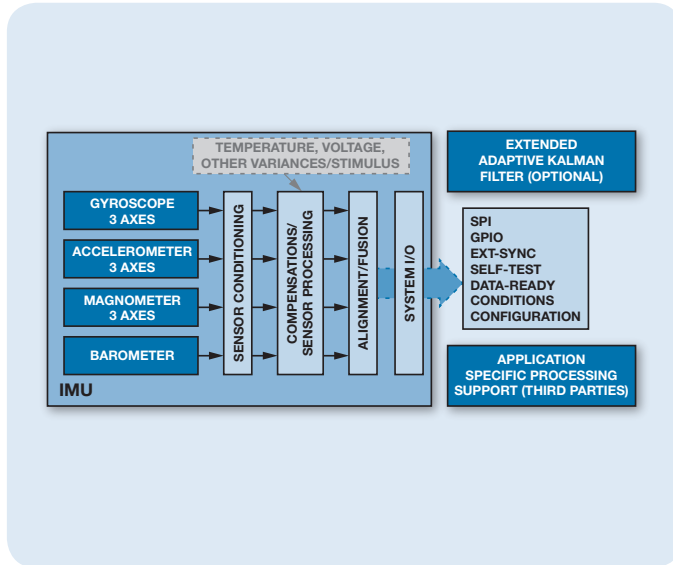

Compact Precision IMUs

- 4 to 10 degrees of freedom
- 0.5 cubic-inch
- >1000°/s range



Tactical Grade IMUs

- 6 to 10 degrees of freedom
- 1.75 cubic-inch
- 2.4 kHz external sync

Common Features

- 4 generations, compatible interface
- Full factory calibration
- Embedded filtering/compensation
- 330 Hz bandwidth

Analog Devices offers the broadest portfolio of high performance MEMS inertial sensors, from component accelerometers and gyroscopes to fully integrated orientation sensors with attitude/heading outputs.

Analog Devices IMU family has targeted solutions for either performance-limited or size-constrained applications, all sharing common interfaces and feature sets, which allows rapid system integration, as well as supporting product generation enhancements.

MEMS Inertial Measurement Unit (IMU) Selection Guide

Part Number	Function	Gyroscopes						Accelerometers		Package Size (mm)	Supply Level (V)
		Range (°/sec)	Linearity (% FS)	Bias Tempco (°/sec/°C)	In-Run Bias Stability (°/hr)	ARW (°/√hr)	Linear-g (°/sec/g)	Range (g)	In-Run Bias Stability (mg)		
4DoF											
ADIS16305	IMU, accel/gyro	±300	0.1	0.006	25	1.9	0.05	±3	0.037	23 × 31 × 6.3	5
ADIS16300	IMU, accel/gyro	±300	0.1	0.1	25	1.9	0.05	±3	0.054	23 × 31 × 6.3	5
6DoF											
ADIS16485	IMU, accel/gyro	±450	0.01	0.0025	6.25	0.3	0.009	±5	0.032	47 × 44 × 14	3.3
ADIS16445	IMU, accel/gyro	±250	0.1	0.005	12	0.56	0.015	±5	0.073	37.7 × 24.2 × 10.6	3.3
ADIS16375	IMU, accel/gyro	±300	0.025	0.005	12	1	0.013	±18	0.1	47 × 44 × 14	3.3
ADIS16367	IMU, accel/gyro	±1200	0.1	0.01	47	2	0.05	±18	0.2	23 × 23 × 23	5
ADIS16365	IMU, accel/gyro	±300	0.1	0.01	25	2	0.05	±18	0.2	23 × 23 × 23	5
ADIS16364	IMU, accel/gyro	±300	0.1	0.01	25	2	0.05	±5	0.1	23 × 23 × 23	5
ADIS16362	IMU, accel/gyro	±300	0.1	0.01	25	2	0.05	±1.7	0.041	23 × 23 × 23	5
ADIS16334	IMU, accel/gyro	±300	0.1	0.01	25	2	0.05	±5	0.1	32.7 × 24.2 × 10.6	5
9DoF											
ADIS16405	IMU, accel/gyro/magn	±300	0.1	0.01	25	2	0.05	±18	0.2	23 × 23 × 23	5
10DoF											
ADIS16488	IMU, accel/gyro/magn/baro	±450	0.01	0.0025	6.25	0.3	0.009	±18	0.1	47 × 44 × 14	3.3
ADIS16448	IMU, accel/gyro/magn/baro	±1000	0.1	0.005	14.5	0.66	0.015	±18	0.11	37.7 × 24.2 × 10.6	3.3
ADIS16407	IMU, accel/gyro/magn/baro	±300	0.1	0.01	25	1.9	0.05	±18	0.2	23 × 23 × 23	5
10DoF Plus											
ADIS16480	IMU, accel/gyro/magn/baro/EKF	±450	0.01	0.0025	6.25	0.3	0.009	±10	0.1	47 × 44 × 14	3.3

Design Resources and Tools

EVAL-ADIS Evaluation System

The EVAL-ADIS is an advanced real-time evaluation system for the ADIS16xxx product family. It supports application software that enables basic demonstration, individual register access, and high speed data capture for each supported device. Each application software package comes with an installation wizard and a simple USB driver package. All IMUs within the *i*Sensor portfolio are supported via the PC-based evaluation setup, providing a common and easy-to-use analysis tool. All software packages associated with the EVAL-ADIS are compatible with Windows® XP, Vista, and 7, and provide USB drivers that are compatible with both 32-bit and 64-bit PC systems.

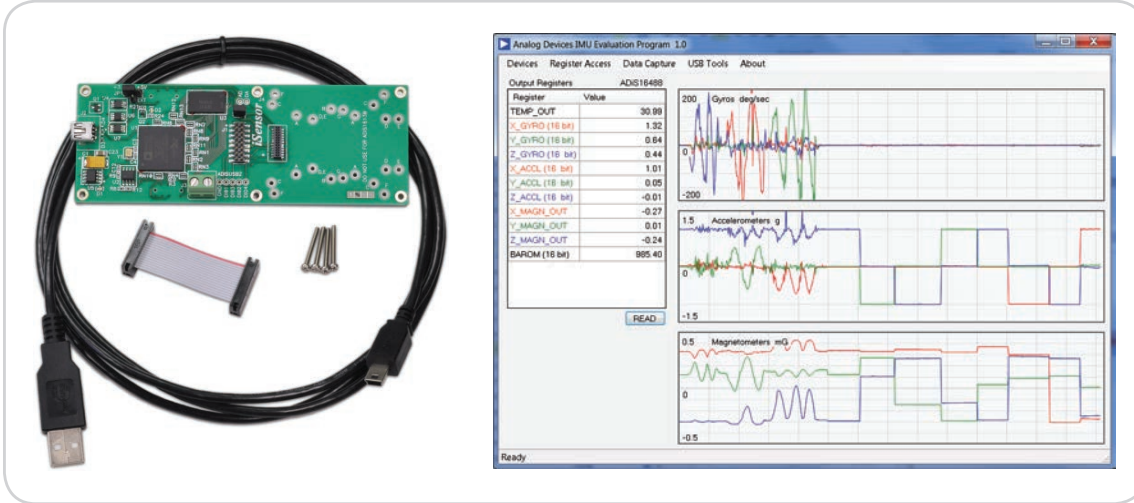

ADISxxxx/PCB Breakout Board

Breakout boards offer a simple method for connecting IMUs to existing embedded processor systems. With just a few lines of code, development work is quickly enabled through the 16-pin interface connector, which provides access to power, ground, and all I/O lines, using standard ribbon cables.

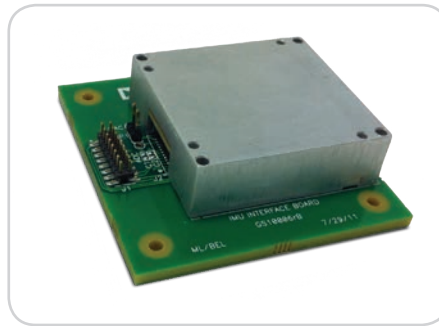

Analog Devices, Inc.
Worldwide Headquarters
Analog Devices, Inc.
One Technology Way
P.O. Box 9106
Norwood, MA 02062-9106
U.S.A.
Tel: 781.329.4700
(800.262.5643,
U.S.A. only)
Fax: 781.461.3113

Analog Devices, Inc.
Europe Headquarters
Analog Devices, Inc.
Wilhelm-Wagenfeld-Str. 6
80807 Munich
Germany
Tel: 49.89.76903.0
Fax: 49.89.76903.157

Analog Devices, Inc.
Japan Headquarters
Analog Devices, KK
New Pier Takeshiba
South Tower Building
1-16-1 Kaigan, Minato-ku,
Tokyo, 105-6891
Japan
Tel: 813.5402.8200
Fax: 813.5402.1064

Analog Devices, Inc.
Southeast Asia Headquarters
Analog Devices
22/F One Corporate Avenue
222 Hu Bin Road
Shanghai, 200021
China
Tel: 86.21.2320.8000
Fax: 86.21.2320.8222

Support Community



Get answers to technical questions about Analog Devices MEMS inertial sensors and connect with fellow engineers and experts around the globe.

ez.analog.com/community/mems

Analog Devices Wiki

Check out the Wiki-based user guides for step-by-step instructions and software, along with tips and tricks for getting the most out of these high performance MEMS evaluation tools.

wiki.analog.com/resources/eval/user-guides

The *i*Sensor MEMS IMU Evaluation Software Getting Started Guide is available to help developers get up and running fast at wiki.analog.com/resources/eval/user-guides/inertial-MEMS/imu/imu-evaluation-software